

COBHAM

SAILOR SP3540 Portable VHF ATEX GMDSS

User manual



Emergency procedure

- Turn the knob at the top of the radio clockwise. The display lights up showing the last used channel and the battery level.
- Select channel 16 (Distress or Safety), press the **16/C key**.
- Press the PTT and say:
 - "MAYDAY, MAYDAY, MAYDAY",
 - "This is" ships name repeated three times
 -
 - "MAYDAY"
 - "This is" ships name and call sign,
 - The ship's position in latitude and longitude or other reference to a known geographical location,
 - The nature of distress and assistance wanted,
 - Any other information which might facilitate the rescue.
 - "OVER"
- Release PTT and listen for answer.

IMPORTANT INFORMATION

Safe use of ATEX equipment:

- Do not change the battery in wet or humid environments.
- Always keep battery connectors dry and clean.
- Use only with Sailor ATEX approved accessories.
Alternatively ATEX approved accessories in compliance with the accessory connector ATEX specification may be used.
- Do not change accessories in wet or humid environments.
- Do not charge the battery in hazardous area.
- For charge of battery use
Part no: 403505A - ATEX CH3505 Compact Charger,
Part no: 403507B - ATEX CH3507 Single Position Charger or
Part no: 403508B - ATEX CH3508 Dual Position Charger
- Use only battery type Sailor B3503 or B3504.
- Do not use a mechanically damaged radio.
- Unpacking of the radio and accessories and the removal of the protective film in front of the display window must not take place in the ATEX protected area.

SP3540 ATEX VHF GMDSS

Document number: 98-124307-L

Release date: 8 April 2021

Copyright: © 2021 Thrane & Thrane A/S. All rights reserved.

Trademark Acknowledgements

- **SAILOR** is a registered trademark of Thrane & Thrane A/S.
- **Other product and company names** mentioned in this manual may be trademarks or trade names of their respective owners.

Warranty limitation

IMPORTANT - The radio and batteries are sealed waterproof units. To create and maintain the waterproof integrity they were assembled in a controlled environment using special equipment. The radio and batteries are not user maintainable units, and under no circumstances should the units be opened except by authorized personnel. Unauthorized opening of the units will invalidate the warranty.

Disclaimer

Any responsibility or liability for loss or damage in connection with the use of this product and the accompanying documentation is disclaimed by Thrane & Thrane A/S. The information in this manual is provided for information purposes only, is subject to change without notice and may contain errors or inaccuracies. Manuals issued by Thrane & Thrane A/S are periodically revised and updated. Anyone relying on this information should acquire the most current version e.g. from www.cobhamsatcom.com, Cobham SYNC Partner Portal, or from the distributor. Thrane & Thrane A/S is not responsible for the content or accuracy of any translations or reproductions, in whole or in part, of this manual from any other source. In the event of any discrepancies, the English version shall be the governing text.

Thrane & Thrane A/S is trading as Cobham SATCOM.

Precautions

Avoid water and salt in the I/O connector and keep it clean frequently.

Only use original Thrane & Thrane battery packs. Make sure they are clean and dry before attaching the transceiver. Be careful not to damage any gaskets.

Only use the original Thrane & Thrane charger for the rechargeable battery.

Be very careful when handling the Lithium batteries. With correct use they are safe but any misuse might cause dangerous situations.

Never short circuit the battery terminals, never expose the transceiver and the batteries to extreme temperature or fire and never use any kind of violence.

Avoid close contact between the antenna and parts of the human body. The top of the antenna must never be closer than 5 cm to the body when transmitting.

Do not submerge the transceiver more than 1 m for 30 minutes.

Keep the transceiver at least 0.3 m away from the magnetic compass.

Training information

SAILOR SP3540 ATEX VHF GMDSS is designed for "occupational use only". It must be operated by licensed personnel only.

The SP3540 complies with the FCC RF exposure limits for "Occupational Use Only".

- FCC OET Bulletin 65 Supplement C, evaluating compliance with FCC guidelines for human exposure to radio frequency electromagnetic fields.
- American National Standards Institute (C95.1) IEEE standard for safety levels with respect to human exposure to radio frequency electromagnetic fields, 3 kHz to 300 GHz.
- American National Standards Institute (C95.3) IEEE recommended practice for the measurement of potentially hazardous electromagnetic fields - RF and microwaves.



Warning! Your Thrane & Thrane VHF radio generates electromagnetic RF (radio frequency) energy when transmitting. To ensure that you are not exposed to excessive amounts of energy and thus to avoid health hazards from excessive exposure to RF energy, all persons must be at least 5 cm away from the antenna when the radio is transmitting.

Correct use

For best performance, hold the radio vertically and 10 cm away from the head when talking into the microphone.

Contents

Chapter 1 Introduction

Your ATEX VHF GMDSS	1
Performance	2
Channels	2

Chapter 2 Operation

Controls	3
Keys and buttons	3
The display	5
Using the ATEX VHF GMDSS	6
Basic functions	6
Other functions	9
Configuring the ATEX VHF GMDSS	11
Entering and using configuration mode	11
Configuration settings	12

Chapter 3 Batteries

Battery types	15
The primary battery	15
The secondary battery	16
Battery level indication	16
Removing and inserting the battery pack	16
The battery charger	17
Installing the charger	17
Recharging the secondary battery	18

Chapter 4 Equipment and accessories

External equipment	19
List of equipment	19
Connecting external equipment	20
Impact on radio operation	20
Accessorie connector	21
Accessories	22
List of accessories	22
Attaching and removing the belt clip	24
Attaching the lanyard	24

Chapter 5 Troubleshooting

Displaying errors	25
-------------------------	----

App. A Technical specifications

Technical data SP3540	27
General	27
Transmitter	28
Receiver	28
Battery life guidelines	29
Primary battery (non-rechargeable)	29
Secondary battery (rechargeable)	29
Dimensional drawing, transceiver	30
Dimensional drawing, chargers	31
Declarations of Conformity	33

App. B Attention

Gore-Tex Membrane	37
--------------------------------	-----------

Introduction

Your ATEX VHF GMDSS

SP3540, your new SAILOR portable VHF transceiver, is approved to fulfil the GMDSS requirements for portable VHF radios for Safety at Sea and is waterproof to the IP67 standard.

As part of the required safety equipment, the SAILOR SP3540 is to be used in an emergency situation. However the best way to guarantee functionality in an emergency situation, is to use the radio in daily communication on board.

The SP3540 is designed for daily use and it connects easily to external equipment like headsets and fist mikes, making the SP3540 suitable for any noisy environment.

The unique battery concept makes the radio suited for both daily use and emergency situations. The primary emergency battery is to be stored for emergency situations and a secondary rechargeable battery can be used for daily communication in your new portable VHF transceiver.

The radio is designed with a unique man machine interface, an excellent grip even with gloves, and large tactile buttons.

The display has red adjustable backlight which makes the display visible even at night, without violating the night vision.



The radio is equipped with a lanyard and a belt clip. A huge accessory program comes with the SAILOR SP3500 series.

Please find the nearest SAILOR distributor on www.cobham.com.

Performance

For best performance of the transceiver keep the following in mind:

- Keep clear of metal environment.
- Hold the transceiver vertically and 10 cm from lips and push the PTT when transmitting.
- In receive mode carry the transceiver vertically with belt clips.
- To preserve battery power, adjust squelch to close the loudspeaker when there is no signal.
- If you are in a lifeboat keep the antenna as high as possible.

Channels

This radio operates with the following channels according to the Radio Regulations Appendix 18.

Note | Channel designators xxA corresponds to 10xx defined in the Radio Regulations Appendix 18.

6	12	17	67	73	78A
8	13	19A	68	74	79A
9	14	20A	69	75 L)	87
10	15	27A	71	76 L)	88
11	16	28A	72	77	

L) Tx power is limited to 1 W.

Operation

Controls





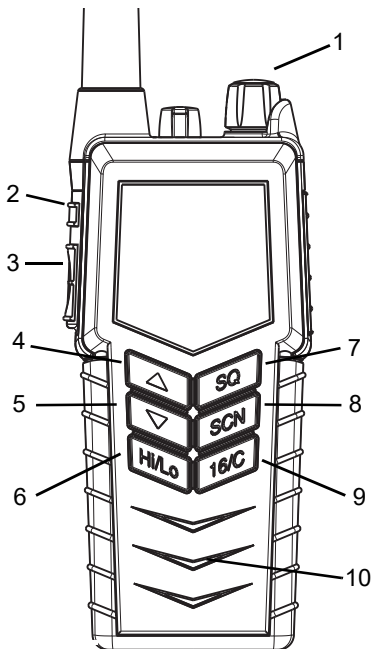

Keys and buttons

1. On/off/volume
2. Light/Lock
3. Push To Talk (PTT)
4. Up key
5. Down key
6. Hi/Lo output power
7. Squelch
8. Scan
9. Priority channel (16)/
Call channel
10. Loudspeaker/microphone



Key presses

Pressing and holding certain keys gives access to additional functions, shown in the table below.

Key	Short press (1 beep)	Long press (2 beeps)	Extra long press (3 beeps)
 	<p>Show next available item in the list (up or down).</p> <p>Default: Channel selection</p>	<p>Run through available items, or select tagged channels A (▼) or B (▲).</p>	<p>Run through available items if an A or B channel is tagged</p>
	<p>Activate Squelch control (Adjust with up/down arrows).</p>	<p>Monitor function. Open Squelch completely.</p>	
	<p>1 press: Activate/terminate Dual/Triple watch.</p> <p>2 presses: Activate memory scan.</p>	<p>Add/Delete channel from memory scan.</p>	
	<p>Toggle between high and low transmitter power.</p>		
	<p>Select channel 16.</p>	<p>Select programmed Call channel.</p>	<p>Program Call channel.</p>

The display

The display holds various fields of information, explained below.

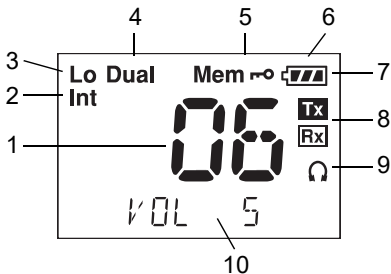

1. Current working channel.
2. Current channel mode.
3. “Lo”: Reduced transmitter power.
Full transmitter power is not shown in display.
4. Dual watch activated.
5. Current working channel is marked for scanning.
6. Keypad is locked.
7. Battery level indicator.
8. Transmitting (Tx) /Receiving (Rx).
9. Accessory is connected.
10. Service line for various purposes. In this example the volume level.

Using the ATEX VHF GMDSS

Basic functions

Note Before using the radio, mount the antenna at the top of the radio. The antenna is delivered with the radio.

Switching the radio on and off

- **To switch the radio on**, turn the knob at the top of the radio **clockwise**.
The display lights up showing the last used channel and the battery level.
- **To switch the radio off**, Turn the knob back **counter-clockwise** until it clicks.



Selecting the working channel

- To select **channel 16** (Distress or Safety), press the **16/C** key.
- To select the **Call channel**, use a long press on **16/C**.
- To select among **all available channels**, press **▲** or **▼** on the keypad.
For fast selection, press and hold **▲** or **▼**.

The display shows the currently selected channel.

Note Long press on **▲** or **▼** can also be used to select preferred channels. For information on how to program preferred channels, see *Configuring the ATEX VHF GMDSS* on page 11.

Activating a call

To **activate a call** to the selected channel, press and hold the **PTT** button on the side of the radio.

The radio transmits as long as the PTT button is pressed. A small **Tx** sign next to the channel number indicates when the radio is in transmit mode.

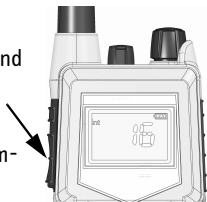

Adjusting the volume

- To **increase** the volume, turn the on/off knob at the top of the radio **clockwise**.
- To **decrease** the volume, turn the knob **counter-clockwise**.

The display shows the level of the volume, e.g. “VOL 5”, while it is adjusted.

Using Squelch control

- To **activate** Squelch control, press the **SQ** key.
- To **set** the Squelch level, press ▲ (closing) or ▼ (opening). The display shows the Squelch level while it is adjusted, e.g. “SQ 5”.

Adjusting the display backlight

- To **turn on** the backlight, press the **Light/Lock** button on the side of the radio.
- To **adjust** the backlight level, press ▲ or ▼ within 3 seconds after turning on the light. The display shows the level while it is adjusted, e.g. “DIM MED”.



Using Dual watch

To activate Dual watch, press the **SCN** key.

The display shows “Dual” at the top and “16” at the bottom right.

The radio toggles between the selected channel and channel 16.

- **To terminate** Dual watch, press **SCN** again.

Scanning channels

- **To activate** scanning memory, press 2 times **SCN** within 2 seconds.

During scanning, the display shows “SC” in the channel field. The

radio toggles between channel 16 and each of the channels marked for scanning.

- **To terminate** scanning, press **SCN** once.

Changing the transmitter power

To change the transmitter power, press the **Hi/Lo** key. The display shows

“Lo” when power is set to low. Otherwise maximum power is used.

Locking the keypad

- **To lock** the keypad, press and hold the **Light/Lock** button. The display

shows a key symbol when the keypad is locked.

- **To unlock** the keypad, press and hold the **Light/Lock** button again.

Other functions

Programming the Call channel

To program the Call channel, do as follows:

1. Press and hold **16/C** until the current Call channel number is flashing.
2. Select the channel with **▲** or **▼**.
3. Press **16/C** to confirm.

Programming the scanning memory

To add a channel to the scanning memory, select the channel and then press and hold the **SCN** key until the display shows **MEM** at the top.

To remove a channel from the scanning memory, select the channel and then press and hold the **SCN** key until the **MEM** sign disappears from the display.

Alive beep

To enable "ALIVE" function do as follows:

1. Select the channel where ALIVE function is desired to be transmitted.
2. Press and hold the **Hi/Lo** until you see "ALIVE ON" on the radio display. It takes approx. a second.
3. Now "ALIVE" is transmitted by a "beep" on the working channel, with approx. 4-second intervals.

To deactivate "ALIVE" function do as follows:

- Press and hold the **Hi/Lo** pressed until "ALIVE ON" no longer appears on the radio display. It takes approx. a second.

“ALIVE” function is also deactivated when

- The channel is changed.
- The radio is turned OFF and ON again.
- Watch or scanning is enabled.
- Squelch is open.

Refer to *ALIVE* on page 13

Configuring the ATEX VHF GMDSS

Entering and using configuration mode

Note | The radio is not operational in configuration mode.

- **To enter** configuration mode, press and hold the **Light/Lock** button while turning on the radio.
The bottom line of the display shows the current menu item/setting.
- **To exit** configuration mode, turn off the radio or press any key except **▲**, **▼** and the Light/Lock button.
Using the PTT button or leaving the radio inactive for 10 seconds also causes the radio to exit configuration mode.
- **To change** a setting, press **▲** or **▼**.
- **To confirm the current setting** and go to the next menu item, press the **Light/Lock** button.

Configuration settings

Configuration mode is used to program preferred channels and volume of key beep and battery alarm.

The following settings are available in configuration mode.

BEEP	MAX	Status click/beep sound on key press, long press (settings/programming saved) and battery alarm. Maximum level.
	MIN	Status click/beep sound on key press, long press (settings/programming saved) and battery alarm. Minimum level.
	OFF	All beeps off.
PREFA	OFF	Remove tag "A" for current working channel.
	ON	Tag current working channel with "A". If another channel was previously tagged "A", this is overruled. <ul style="list-style-type: none"> The working channel can now be selected with a long press on ▼.
PREFB	OFF	Remove tag "B" for current working channel.
	ON	Tag current working channel with "B". If another channel was previously tagged "B", this is overruled. <ul style="list-style-type: none"> The working channel can now be selected with a long press on ▲.
VER	X.XX.XX	Software version. Read-only.

ALIVE	OFF	Factory default state.
	ON	Press ▲ to set “ALIVE” on.
ADD NAME	A-Z, 0-9	Makes it possible to name the channels. The name must contain a maximum of 9 characters, use only capital letters, digits and spaces. Press Light/Lock to confirm programming. Note: The name appears in the service line on the display.

Batteries

Battery types

- The orange primary battery pack contains a non-rechargeable Lithium battery. This battery pack is only to be used in case of emergency.
- The blue secondary battery pack contains a rechargeable battery. This battery pack is for daily use.

The primary battery

Important

The orange primary battery pack is only for emergency use, and is **not** rechargeable.

Before using the primary battery, remove the seal on the battery pack.

Then do as follows:

1. Attach the battery pack to the radio as shown.
2. Lock the battery with the safety lock at the bottom.

The primary battery is capable of providing sufficient power for 8 hours of operation defined as 10% Tx, 10% Rx and 80% standby.

When the primary pack is not in use it must always be placed in the dedicated rear position in the charger cradle, see *The battery charger* on page 17.

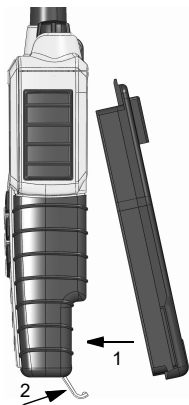

The secondary battery

Battery level indication

The blue secondary battery pack is for daily use of the radio. When the battery level is low, you should recharge the battery.

The radio display shows the battery status. When the battery symbol is empty and flashing, the battery should be recharged as soon as possible.

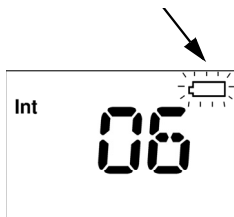

Removing and inserting the battery pack

To remove the battery pack, do as follows:

1. Open the safety lock as shown.
2. Remove the battery.

To insert the battery pack, attach the battery and close the safety lock as shown on the previous page.

If the radio is not used for several weeks it is recommended to store the radio and battery separated to reduce self discharge of the battery.

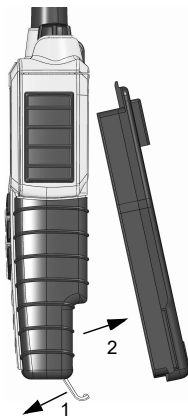

The battery charger

The chargers has two compartments.

CH3505

- A compartment for recharging the battery alone or while attached to the radio.

CH3507

- A rear compartment only for storing a spare battery. It does not have a charger function.
- A front compartment for recharging the battery alone or while attached to the radio.

CH3508

- It is possible to charge a battery in rear compartment simultaneously with the radio/battery in front.

Installing the charger

Mounting the charger

There are several options for mounting one or more chargers on a table or a wall.

For information on dimensions and screw positions, refer to Dimensional drawing, charger on page 27.

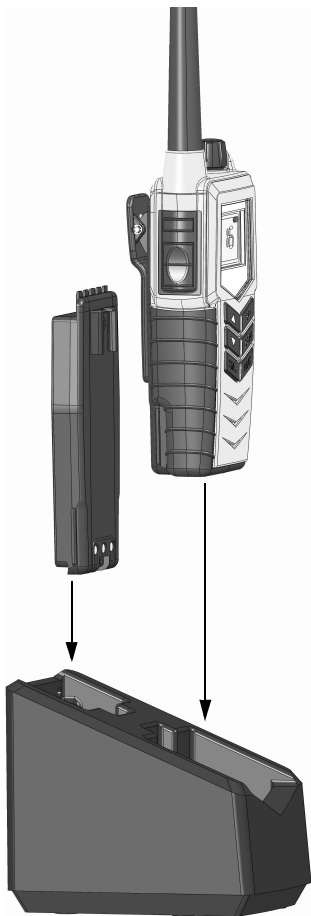

When mounting the charger, make sure it is placed in a dry place and away from direct sunlight. The charger is not waterproof.

Connecting to power

The charger can be supplied with DC or AC.

DC: Connect the 12-24VDC Connection Cable between the DC supply and the connector on the underside of the charger.

AC: Connect the AC/DC adapter to the connector on the underside of the charger. Then connect the AC/DC adapter to the AC outlet.

Recharging the secondary battery

Important | Do not attempt to recharge the orange primary battery!

To recharge the secondary battery, place the radio with battery or the battery alone in the front position of the charger cradle.

If the radio cannot turn on due to complete discharged battery, then **turn off** the radio and place it in the charger or charge the battery alone.

The light indicators on the charger cradle show the status as follows:

- Green light: Power is connected to the charger.
- Steady red light: Charging completed. Trickle charge mode.

Charging time with empty battery: VHF off approx. 4 hours, VHF on: approx. 5 hours.

The battery indicator on the radio display indicates if the radio is placed in the charger while radio and charger are both powered.

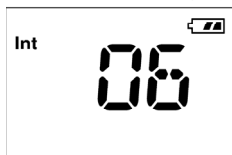

Equipment and accessories

External equipment

List of equipment

The following equipment can be connected to the radio:

Equipment	Order number
SAVOX C-C440AV Push-To Talk unit	403900-942
SAVOX C-C500 Remote Speaker Microphone	403500-944
SAVOX NC/400 Noise-com	403500-003
SAVOX HC-E Helmet-com	403500-004
SAVOX HC-1 Helmet	403500-005
Peltor MT7H79F-50 Headset	403500-006
Peltor MT7H79P3E-50 Headset - Helmet Mount	403500-007
Peltor MT1H7F2-07-51 Tactical ATEX - Headband	403500-008
Peltor MT1H7P3E2-07-51 Tactical ATEX - Helmet	403500-009

We recommend to remove all accessories during emergency use.

All accessories listed might be used when body worn.

Connecting external equipment

Connect the dedicated interface cable between the external equipment and the top connector on the radio.

Interface cable	Order number
SAVOX C-C440AV - for SAVOX PTT unit	403900-942
SAVOX C-C500 - for SAVOX Headset	403500-944
SAVOX C-C500/C-C440 - for PELTOR headset when using SAVOX PTT	403900-953
Peltor FL5261 - for Peltor Headset	403500-952



When external equipment is connected to the radio, the right side of the display will show a headset.



Impact on radio operation

The external equipment can have a built-in PTT button, speaker and microphone. Thus a connection has per default the following impact on the radio operation:

- If a speaker or earpiece is built into the detected external equipment, the sound device of the external equipment is used, and the internal radio speaker is disabled.

- The external accessory microphone is selected as audio input device, when the external PTT button is pressed. The transceiver microphone is used as audio input device when the transceiver PTT button is pressed.
- This behaviour can be changed in the service tool.

Accessorie connector

- Pin 1. Loudspeaker,
minimum 8 ohm impedance.
- Pin 2. Accessory power,
3.5V maximum 13mA.
- Pin 3. Microphone input,
 $R_i = 2.2\text{kohm}$, 3V phantom power.
- Pin 4. GND.

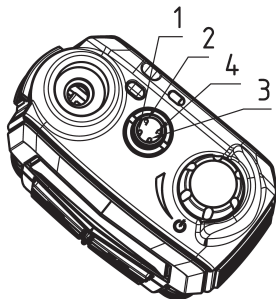

Accessories

List of accessories

The following accessories are delivered with your radio:

Accessory	Part number
ATEX Primary battery (orange, non-rechargeable), B3503	403503A
ATEX Secondary battery (blue rechargeable), B3504	403504A
ATEX Charger, CH3507	403507B
AC/DC converter, length 150cm (100-240V~ /12VDC out)	88-125538
12-24VDC Connection cable, length 150cm	37-124381
Belt clip	62-124320
Antenna	88-124370
Lanyard	41-124375
User Manual (this manual)	98-124307

Batteries, charger, AC/DC Converter and **12VDC Connection** are described in Batteries on page 13.

To mount the **antenna**, simply screw it into the threaded bush at the top of the radio.

Use of **lanyard** is only for hand held operation. Put it around the wrist to prevent dropping the radio.

Accessories you may buy

Accessory	Part number
ATEX Compact Charger CH3505	403505A
ATEX Dual Position Charger CH3508	403508B
ATEX Leather Case with shoulder strap	403500-207

Leather Case**Warning!**

The display must always be kept away from the body to reduce the RF exposure when body worn.

Attaching and removing the belt clip

To attach the belt clip, slide the belt clip upwards into the rails at the back of the radio until it locks.

To remove the belt clip, press the projection at the top of the belt clip to release the lock and slide the belt clip downwards out of the rails.

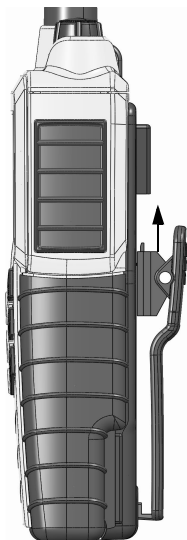
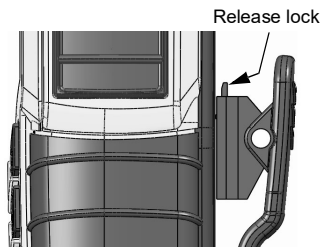

Attaching the lanyard

Do as follows:

1. Take the lanyard through the eye at the top of the radio.
2. Put one end of the lanyard through the loop at the other end of the lanyard and pull to tighten.

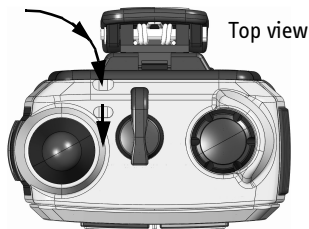

Troubleshooting

Displaying errors

Some errors result in an error message in the display. These error messages are listed below.

Display text	Problem	Type	Actions
Err EMPTY BAT	The battery voltage is below a critical level, where further operation would damage the battery.	Severe. Radio is non-functional.	Change/recharge the battery.
Err HW ERR	Hardware error.	Severe. Radio is non-functional.	Service required.
ILLEGAL	Context fails operation. This text will appear on the following occasions: <ul style="list-style-type: none"> • Multiple watch is selected on channel 16, or in channel regions where it is not allowed. • High power is selected on a channel where it is prohibited. • Transmission on blocked channels 	Fail operation	Consider operation in a different context.

Technical specifications

Technical data SP3540

General

Item	Specification
RX frequency range	155.000 - 163.425 MHz
TX frequency range	155.000 - 161.450 MHz
Modulation	16K0G3E
Power supply	7.4 VDC Li battery
Current drain at 2 W TX	1.2 A
Current drain at 1 W TX	0.8 A
Current drain RX max audio	0.25 A
Antenna port	50 ohm
Primary Battery	Lithium Iron Disulfide, 3000 mAh
Secondary Battery	Lithium-Ion, 1650 mAh rechargeable
Operating temperature	-20°C to +55° C
Water ingress protection	IP67
Frequency stability	Better than ± 0.7 kHz
Weight with emergency battery	390g

Transmitter

Item	Specification
RF output power	2 W /1 W
RF output power, Canada	1.7 W \pm 0.7 dB / 0.8 W \pm 1 dB
Max deviation	\pm 5 kHz
Spurious emission	< 0.25 μ W
Adjacent channel power	> 70 dB

Receiver

Item	Specification
Sensitivity (20 dB SINAD)	-117 dBm typical
Intermodulation	Better than 70 dB
Spurious response	> 70 dB
Adjacent channel selectivity	> 70 dB
Audio output, internal	0.25 W at 10% dist.
Audio output, external	0.25 W/8 ohm

Battery life guidelines

Primary battery (non-rechargeable)

The primary non-rechargeable battery pack is capable of providing sufficient power for the specified 8 hours according to regulations.

The expiry date printed on the battery label is valid when the battery is stored at temperatures below +40°C.

The expiry date will typically be more than 5 years from the purchase date.

Replace the battery at or before this date.

To ensure a long lifetime keep the battery in the store position in the charger and avoid high temperature and direct sunlight.

Secondary battery (rechargeable)

Note

New batteries should be placed in the charger for minimum 12 hours first time.

During daily use, always keep the battery fully charged and away from hot areas.

Keep the battery terminals dry and clean.

Never discharge beyond the specifications of the battery.

Operation/Standby time depends on usage. Generally, the more the radio is transmitting, the faster it will drain the battery. Also, the “Hi” power setting will drain the battery faster than the “Lo” setting.

Approximate figures are:

- A battery can be stored for 4 to 6 month at 25°C if charged to 40%.
- The battery will normally last for 5 to 9 hours of use on a fully charged battery.

Dimensional drawing, transceiver

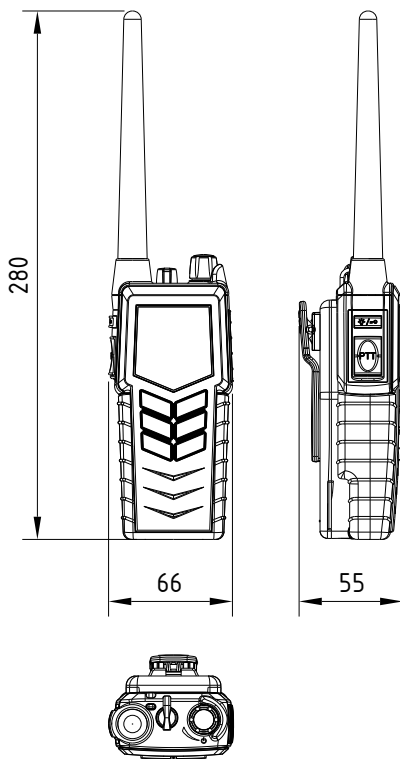

Dimensional drawing, chargers

CH3505

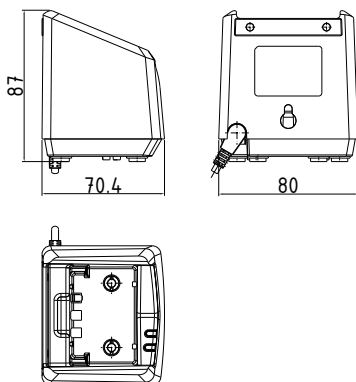

Mounting Possibilities

Desktop mounting, top view

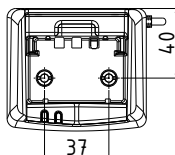

Wall mounting, rear view

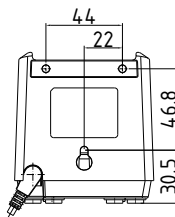

CH3507 and CH3508

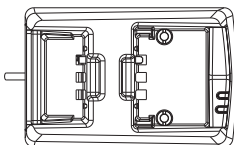
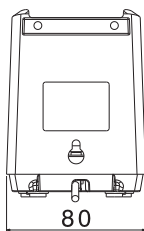
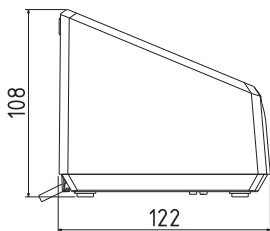

Mounting Possibilities

Desktop mounting, top view

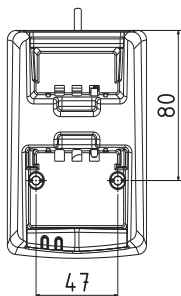

Wall mounting, rear view

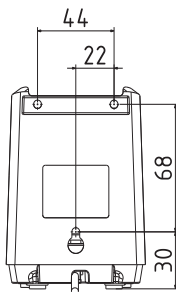

Declarations of Conformity

COBHAM		
Thrane & Thrane A/S		
Declaration of Conformity with ATEX Directive 2014/34/EU		
The object of the declaration described below is in conformity with the relevant Union harmonization legislation: Directive 2014/34/EU.		
Equipment		
SAILOR SP3540	ATEX Portable maritime VHF GMDSS radiotelephone	PN = 623540A
SAILOR B3503	ATEX Primary Battery	PN = 403503A
SAILOR B3504	ATEX Rechargeable Li-Ion Battery	PN = 403504A
Associated equipment for use in non-ATEX area		
SAILOR CH3505	Battery Compact Charger for ATEX	PN = 403505A
SAILOR CH3507	Battery Charger for ATEX	PN = 403507B
SAILOR CH3508	Dual Battery Charger for ATEX	PN = 403508B
	AC/DC Adapter	PN = 88-125538
Equipment Applicability		
SAILOR SP3540 is a simplex/semi duplex VHF radiotelephone, designed for maritime communication within the Global Maritime Distress and Safety System, GMDSS.		
SAILOR SP3540 is able to operate on all International VHF channels.		
Declaration		
The requirement with respect to the ATEX Directive 2014/34/EU is met by conforming to the harmonized EU standards EN 60079-0:2018 and EN 60079-11:2012.		
SP3540 meets the ATEX requirement for gas environments of class II 2 G Ex ib IIC T4		
SP3540 also meets the requirement for Ingress Protection to the level of IP67.		
Manufacturer		
Thrane & Thrane A/S Lundtoftegårdsvej 93D, 2800 Kgs. Lyngby, Denmark		
Industrivej 30, 9490 Pandrup, Denmark		
Certificate		
TÜV 08 ATEX 353822 X		
Place and Date		
Pandrup, 18 January, 2021		
 _____ Program Director R&D Peter Haslev		 2261  ISO 9001 • ISO 14001 <small>DNV-GL Management System Certification</small>
Document number: 99-129012-G		
<small>Thrane & Thrane A/S trading as Cobham SATCOM Lundtoftegårdsvej 93D, 2800 Kgs. Lyngby, Denmark T: +45 39 55 88 00 - F: +45 39 55 88 88 - Comp. reg. 03 72 46 18 - SATCOM.info@cobham.com - cobham.com</small>		

Translation

(1) **EC-Type Examination Certificate**

TÜV NORD

- (2) Equipment and protective systems intended for use in potentially explosive atmospheres, **Directive 94/9/EC**



- (3) **Certificate Number** TÜV 08 ATEX 353822 X
- (4) for the equipment: Radio Transceivers
Type: SAILOR SP3540 VHF GMDSS
- (5) of the manufacturer: **Thrane & Thrane A/S**
- (6) Address: Porsvej 2
DK-9200 Aalborg SV, Denmark
- Order number: 8000353822
- Date of issue: 2008-12-29

- (7) This equipment or protective system and any acceptable variation thereto are specified in the schedule to this certificate and the documents therein referred to.
- (8) The TÜV NORD CERT GmbH, notified body No. 0044 in accordance with Article 9 of the Council Directive of the EC of March 23, 1994 (94/9/EC), certifies that this equipment or protective system has been found to comply with the Essential Health and Safety Requirements relating to the design and construction of equipment and protective systems intended for use in potentially explosive atmospheres given in Annex II to the Directive. The examination and test results are recorded in the confidential report No. 08 203 353822.
- (9) Compliance with the Essential Health and Safety Requirements has been assured by compliance with:

EN 60079-0:2006

EN 60 079-11:2007

- (10) If the sign "X" is placed after the certificate number, it indicates that the equipment or protective system is subject to special conditions for safe use specified in the schedule to this certificate.
- (11) This EC-type examination certificate relates only to the design, examination and tests of the specified equipment in accordance to the Directive 94/9/EC. Further requirements of the Directive apply to the manufacturing process and supply of this equipment. These are not covered by this certificate.
- (12) The marking of the equipment or protective system must include the following:

 **II 2G Ex ib IIC T4**

TÜV NORD CERT GmbH, Langemarkstraße 20, 45141 Essen, accredited by the central office of the countries for safety engineering (ZLS), Ident. Nr. 0044, legal successor of the TÜV NORD CERT GmbH & Co. KG Ident. Nr. 0032

The head of the certification body

Schwedt

Hannover office: Am TÜV 1, 30519 Hannover, phone +49 (0)511 986 1455, Fax +49 (0)511 986 1590

This certificate may only be reproduced without any change, schedule included.
Excerpts or changes shall be allowed by the TÜV NORD CERT GmbH

page 1/3



(13) **SCHEDULE**

(14) **EC-Type Examination Certificate No. TÜV 08 ATEX 353822 X**

(15) Description of equipment

The ATEX VHF radio transceiver type SP3540 VHF GMDSS are designed as intrinsically safe for use onboard ships and on land in classified areas Zone 1 and Zone 2.

The SP3540 is a special GMDSS approved radio for use in emergency situations onboard ships. SP3540 are orange and are supplied either from the ATEX Primary battery type B3503 or alternatively the Secondary battery type B3504. The ATEX Primary battery B3503 is orange and can not be charged. The ATEX Secondary battery B3504 is blue and is rechargeable. Charging takes place in the belonging non ATEX charger. Charging takes place outside protected ATEX area. Both the primary and the secondary batteries are constructed with intrinsically safe connection facilities and they can be changed inside the hazardous area and fulfils Ex ib IIC T4 specifications. The cabinet of the radio is designed to fulfil antistatic ATEX requirements even without the accessory leather case.

Technical data

The accessory interface connector on top of radio is intrinsically safe with the following entity parameters:

Uo: 8.4 V
 Io: 0.45 A
 Lo: 10 µH
 Co: 150 nF

Only ATEX certified accessories matching the above mentioned entity parameters must be connected.

Approved accessories:

Charger CH3505	403505A
Charger CH3507	403507B
Charger CH3508	403508B
VHF Antenna	88-124370-A
VHF Antenna	62-124370
Lanyard	41-124375-A
Belt clips	62-124320
Leather case	403500-207
Service cable	403500-958

Ingress protection: IP 67

Permitted range of the ambient temperature - 20 °C to +55 °C

(16) Test documents are listed in the test report No. 08 203 353822.



Schedule EC-Type Examination Certificate No. TÜV 08 ATEX 353822 X

(17) Special conditions for safe use the following 2 conditions should be added:

- Do not charge the battery in wet or humid environments.
- Always keep battery connectors dry and clean.
- Use only with Sailor ATEX approved accessories.
Alternatively ATEX approved accessories in compliance with the accessory connector ATEX specification may be used.
- Do not charge accessories in wet or humid environments.
- Do not charge the battery in hazardous area.
- For charge of battery use
 - Part no: 403505A - ATEX CH3505 Compact Charger.
 - Part no: 403507B - ATEX CH3507 Single Position Charger or
 - Part no: 403508B - ATEX CH3508 Dual Position Charger
- Use only battery type Sailor B3503 or B3504.
- Do not use a mechanically damaged radio.
- Unpacking of the radio and accessories and the removal of the protective film in front of the display window must not take place in the ATEX protected area.

(18) Essential Health and Safety Requirements

no additional ones

Attention

Gore-Tex Membrane

To keep the VHF watertight, it is very important that the Gore-Tex membrane under no circumstances must be damaged/covered or removed.

That is, do not remove the Gore-Tex membrane or place any labels in the area.



98-124307-L

www.cobham.com/satcom

COBHAM